

Tissue Box 2

The length of the finished box is about 1/2 the width of the paper.

To fit Kleenex Pocket Pack tissues, use 9 1/2 inch paper.

Designed by Paul Ee ©1987

based on a design by Francis Ow

Diagrammed by Mari Michaelis ©2011

☉ Start White side up.

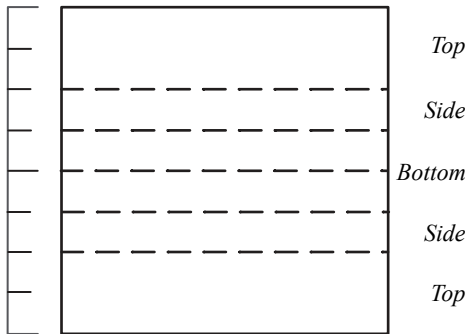

1. Valley fold in 8ths horizontally. Do not fold the bottom & top 8ths.

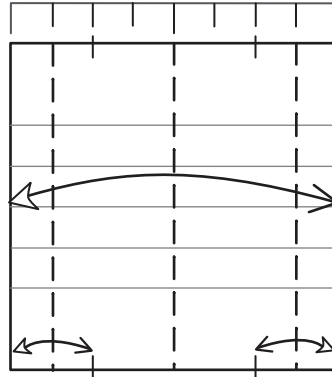

2. Valley fold and unfold in half vertically. Pinch crease at 1/4. Valley fold and unfold the sides to the pinch creases.

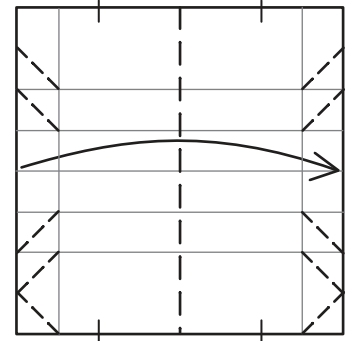

3. Make the diagonal creases to the sides as shown. Then valley fold in half.

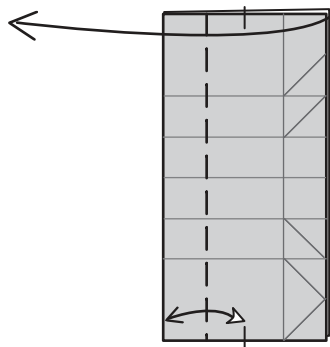

4. Valley fold and unfold to the pinch crease. Unfold to color side up.

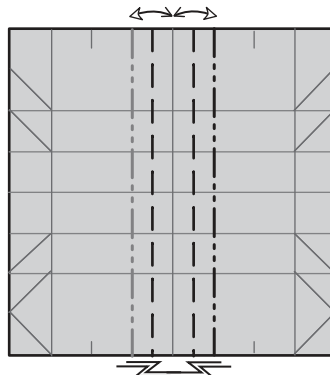

5. Change the right-side crease to a mountain. Bring the mountain creases to the center crease, making a pleat. Unfold and turn over.

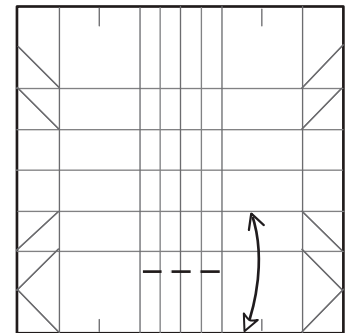

6. Valley fold and unfold the edge to the 3/8ths crease, creasing only in the pleat area.

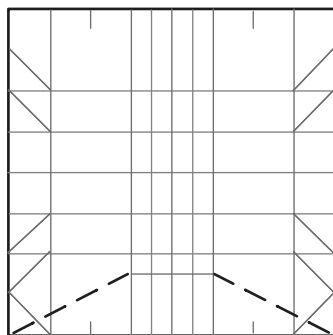

7. Valley fold and unfold from the corner to the crease just made.

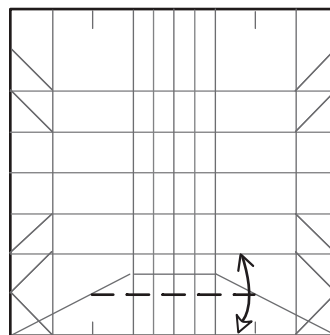

8. Valley fold and unfold from the edge to the 1/4 crease, creasing only between the diagonal creases.

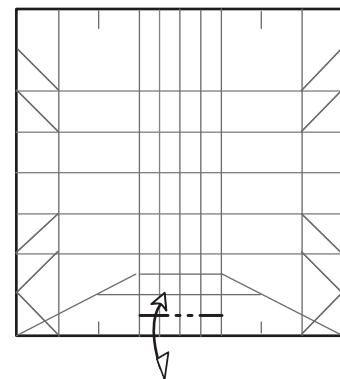

9. Mountain fold and unfold from the edge to the crease just made, creasing only in the pleat area.

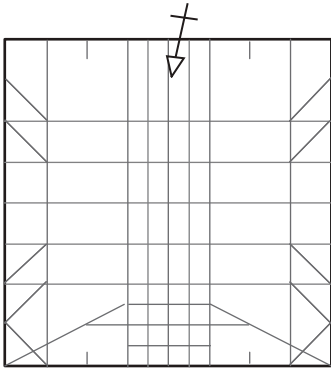

10. Repeat steps 6-9 on the other end.

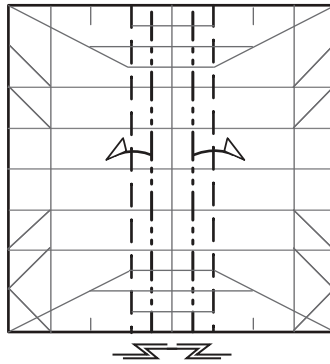

11. Re-pleat the center.

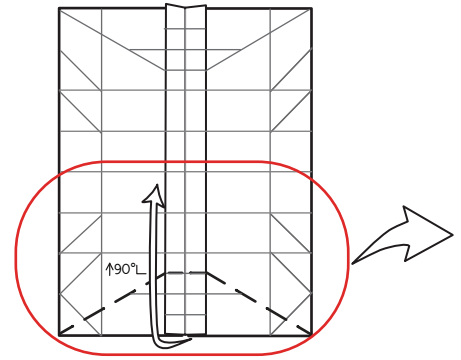

12. Bring the bottom edge straight up on the existing valley crease. Model is 3D. Next view is enlarged detail.

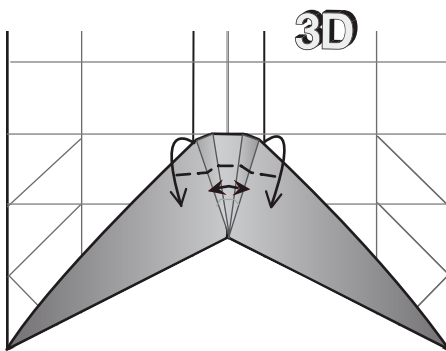

13. To flatten, spread-squash the center pleat from the bottom up. When the top curves down, squash it flat.

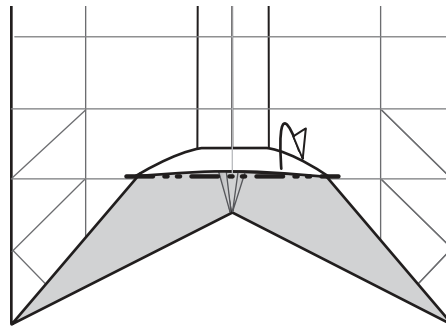

14. Mountain fold behind (lines up with the bottom horizontal crease).

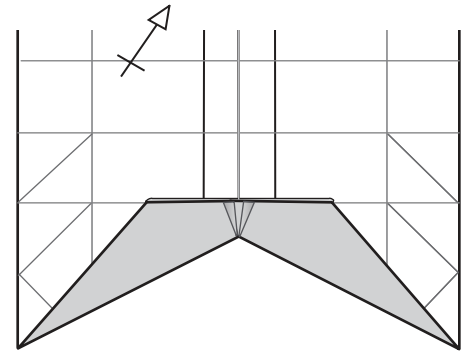

15. Repeat steps 12-14 on the other end.

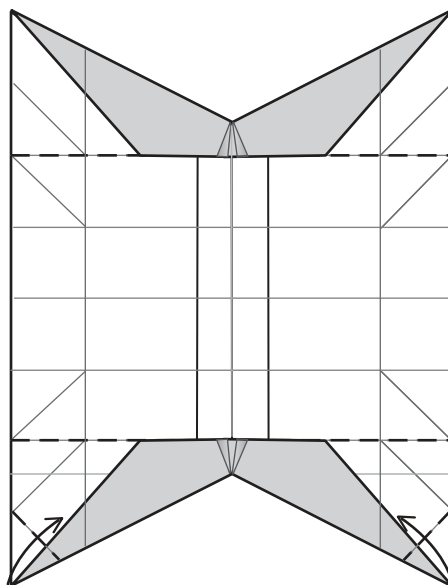

16. Using existing creases, valley fold the bottom corners in diagonally. Reinforce the horizontal valley creases.

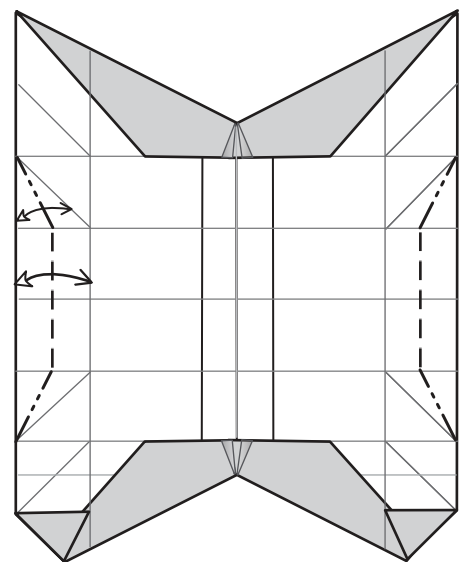

17. Add 2 vertical valley creases and 4 diagonal mountain creases.

Collapsing the model:

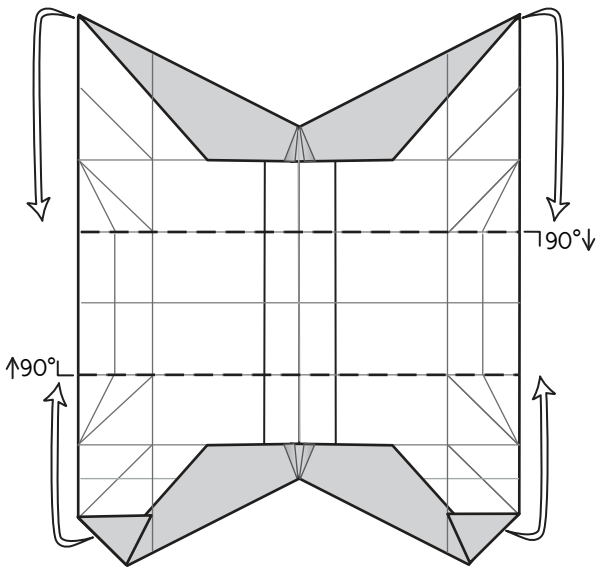

18. Using existing creases, valley fold the top and bottom straight up. Model is 3D.

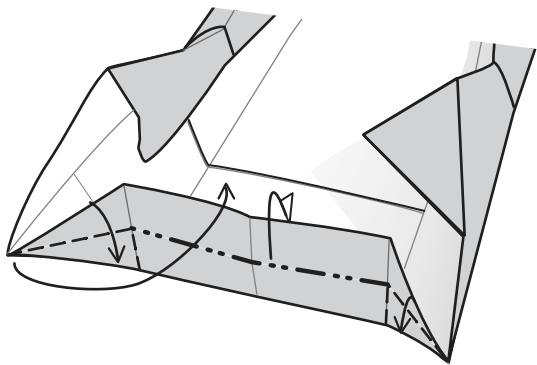

20. Using the creases created in step 17, valley fold the corners bringing the sides inward, while mountain folding the side down.

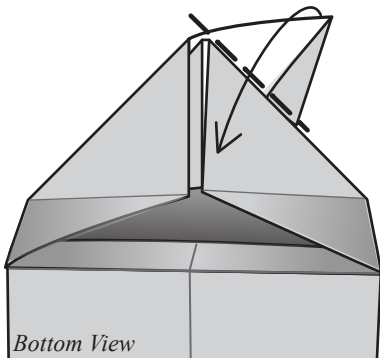

22. Valley fold the flap over the edge.

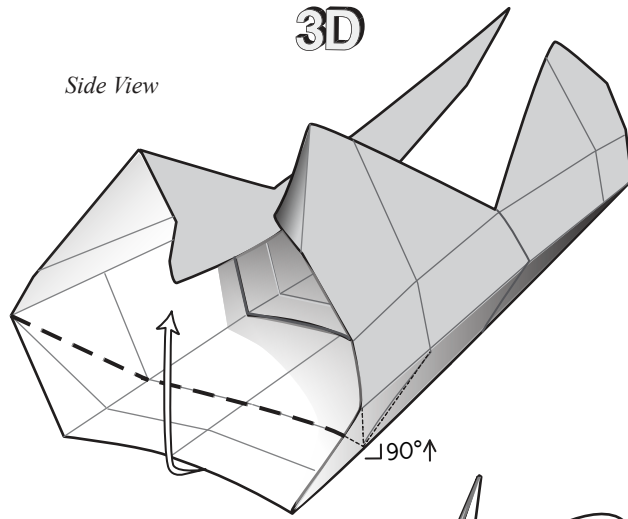

19. Valley fold the side up.

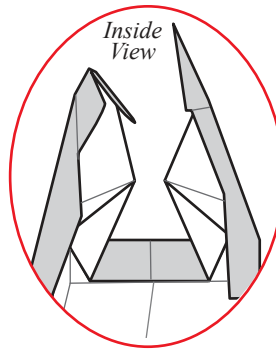

Step 20 completed, inside view.

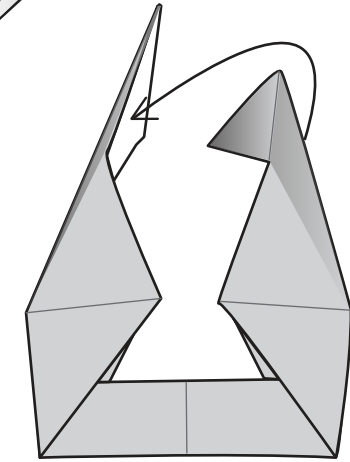

21. Tuck the right flap into the left flap.

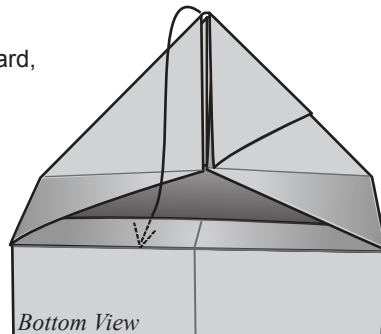

23. Tuck the triangle flap under the side flap.

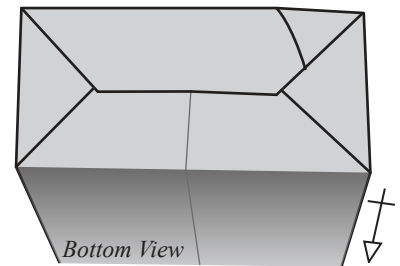

24. Repeat steps 19-23 on the other end and the Tissue Box is complete.

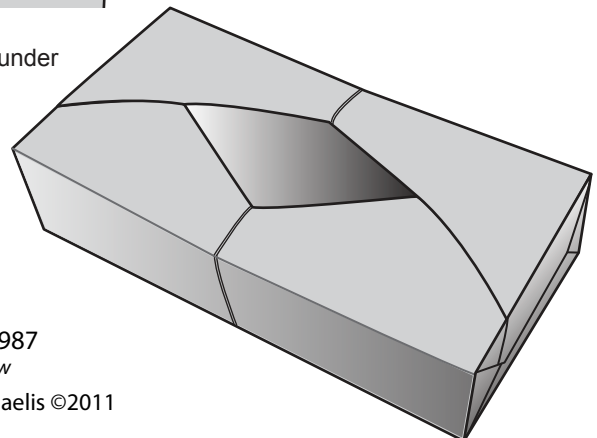

Tissue Box 2

Designed by Paul Ee ©1987
based on a design by Francis Ow

Diagrammed by Mari Michaelis ©2011