

JACOB'S LADDER

"Discovered" by Yami Yamauchi ©1998
 Diagrammed by Mari Michaelis ©2008

SQUARE PANELS VERSION



Paper: Copy paper, 8 1/2 x 11 inch rectangle, minimum 6 sheets.



1. Square off the width of the paper to exactly 8 1/2 inches (actual width of copy paper is a little wider than 8 1/2 inches). Then cut the paper 8 1/2 inches vertically.

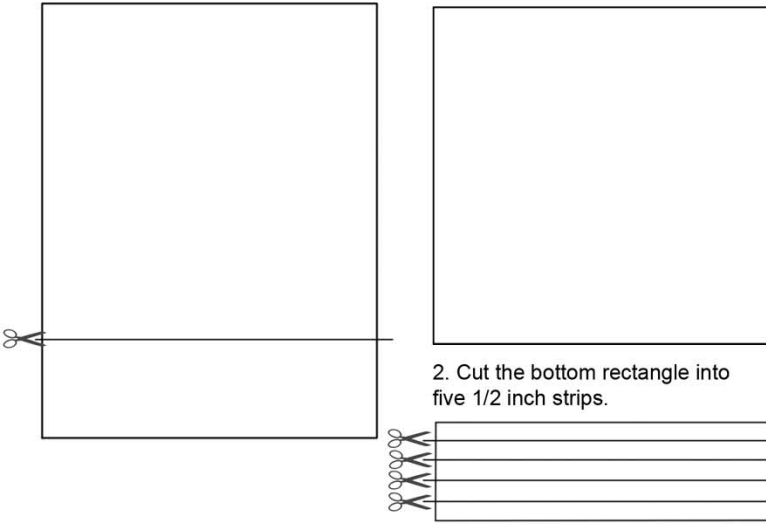

2. Cut the bottom rectangle into five 1/2 inch strips.

3. Valley fold and unfold into 3rds, horizontally and vertically.

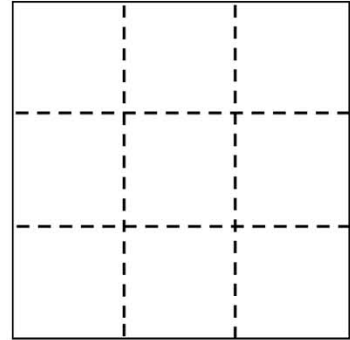

4. Valley fold.

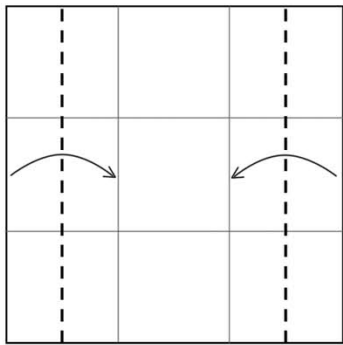

5. Valley fold the sides to the center.

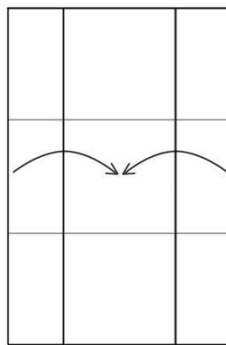

6. Valley fold the 2 bottom corners.

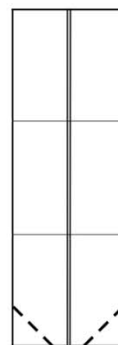

7. Completed unit. Make 6.

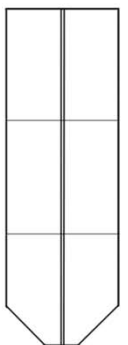

8. Fold the strips: a) Insert one end of a strip into a unit. b) Valley fold the strip to the left. Then wrap the strip loosely around the unit.

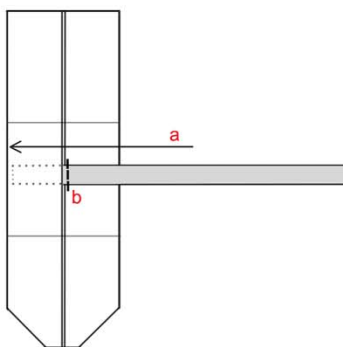

9. Valley fold the last segment of the strip to the right. (Completed shown.) Remove the strip.

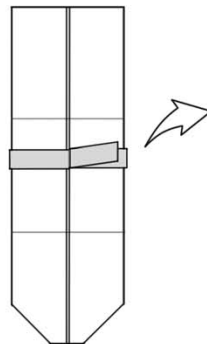

10. Use the strip you folded as a template. For 6 units you'll need 15 strips. (# of units - 1 x 3)

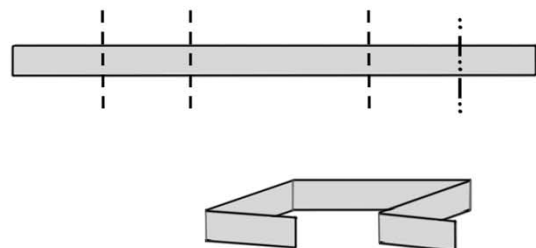

Assembly:

1a. Insert the 3 strips in Unit 1 as shown. Close the unit by folding up the bottom of the unit and inserting it into the pocket at the top. Fold the 2 right strips (Double Strips) over the unit.

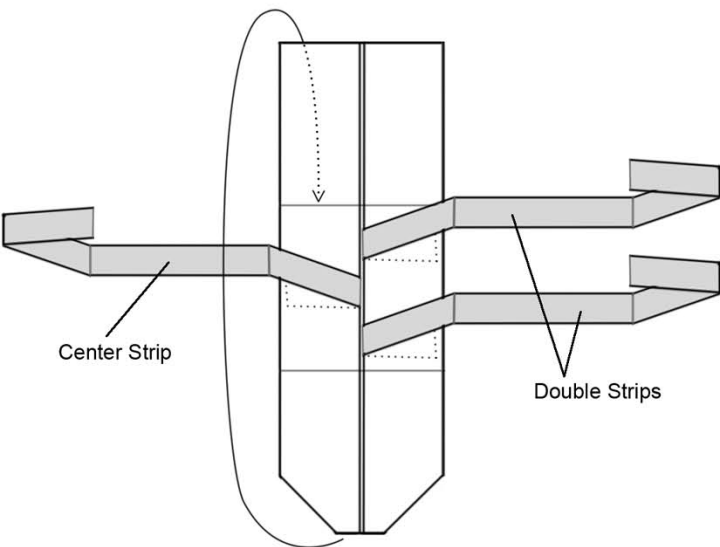

Unit 1 (working right to left)

1b. Unit 1 closed. Note: there are no strips going across *the back* of the first and last units.

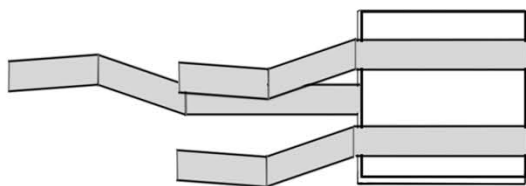

2a. Insert the 3 strips in Unit 2 as shown. The Double Strips are wrapped behind the unit.

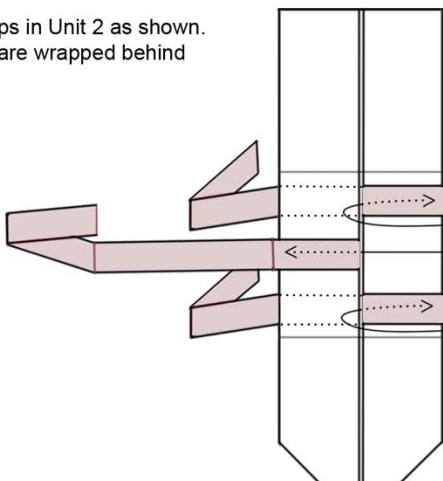

Unit 2

2b. Insert the Double Strips from Unit 1 over the Double Strips of Unit 2. Insert the Center Strip from Unit 1 under the Center Strip of Unit 2.

Be sure that there is enough of a gap between the two units so that the units can move (look at step 2c).

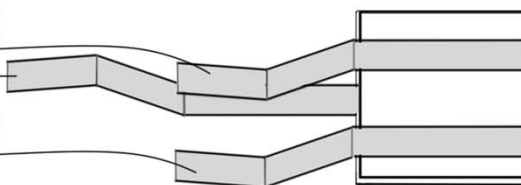

Unit 1

2c. Close Unit 2 *under* the Center Strip from Unit 1.

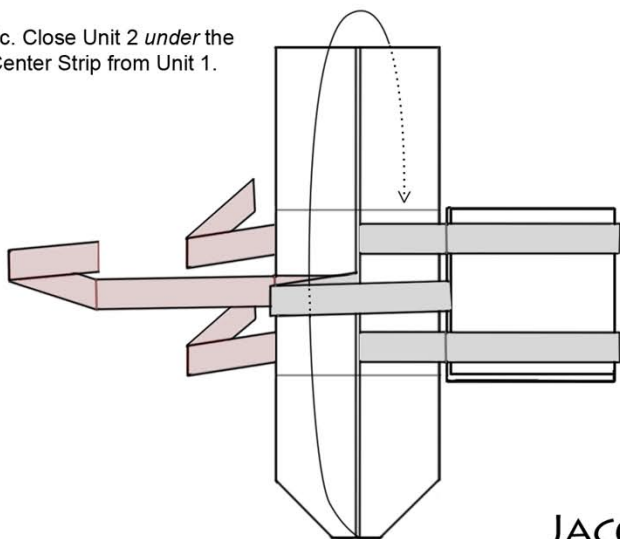

Unit 2

2d. Unit 2 closed.

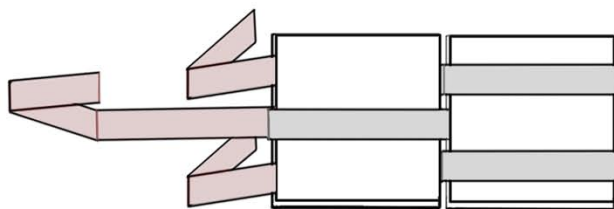

3a. Wrap Unit 2's Center Strip behind Unit 3 and then insert into Unit 3. Insert Unit 2's Double Strips into Unit 3.

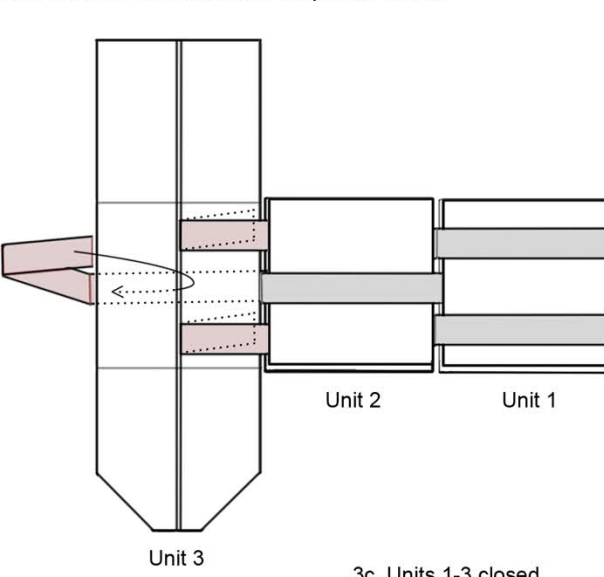

3b. Insert 3 strips into Unit 3 as shown. Close the unit and fold the Double Strips over the top of the unit.

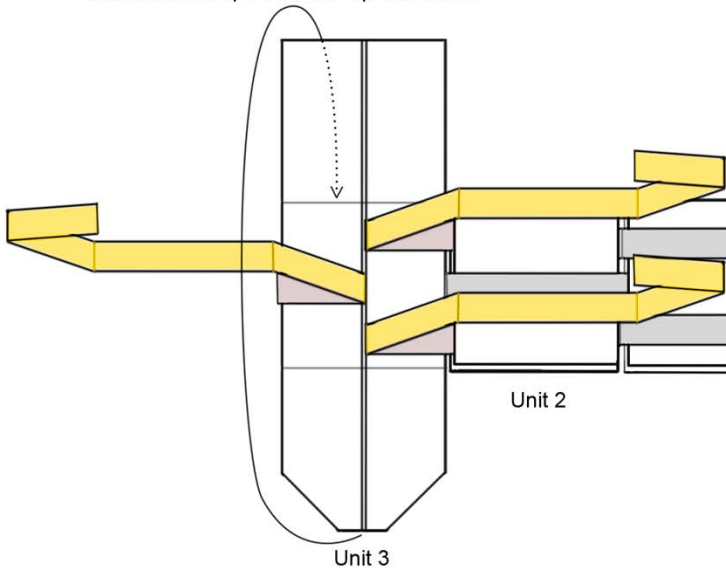

3c. Units 1-3 closed.

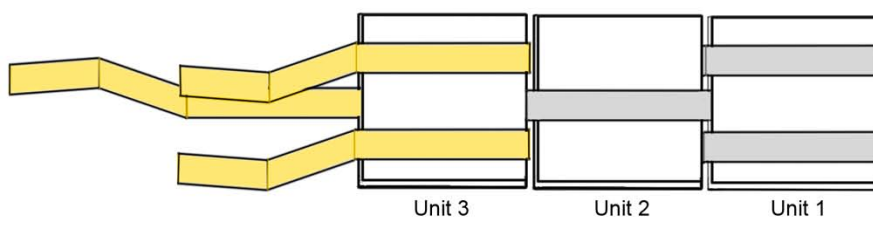

- 4. Insert the strips into Unit 4 in the same way as Step 2a. Attach Unit 3 to Unit 4 in the same way as Steps 2b-2c.
- 5. Insert Unit 4 into Unit 5 in the same way as Step 3a. Add the strips to Unit 5 in the same way as Step 3b.

- 6. Insert Unit 5 into Unit 6 in the same way as Step 2a. Close Unit 6 *under* the Center Strip from Unit 5.

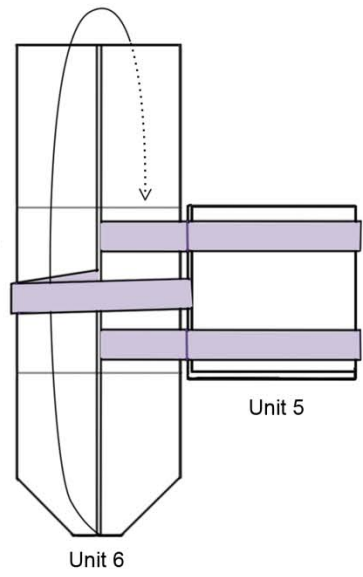

Finished!
To see the model in action, hold an end unit by the sides and tilt it down. The units below it will appear to cascade down the ladder. Tilt the unit back up and the other units will tumble down again.

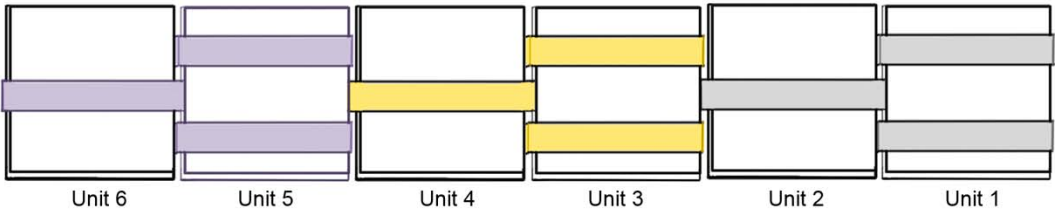
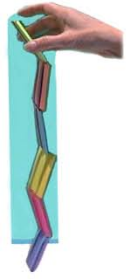

Reverse side:

